

# CONE

by Osiris Hertman

Obsessed with Details — 2026 Collection

# CONE

by Osiris Hertman

# A conical shape

The CONE collection by Osiris Hertman, inspired by the handle on a safe, is characterized by its elegance and timeless aesthetic. The neck of the door handle is tapered, resulting in its characteristic conical shape. The rose-less design also creates the illusion of a floating door handle. The door handle is manufactured as one piece, making it a technical masterpiece, especially with the extremely high-standard finish applied. The seamless design imbues a space with a sense of tranquillity while substantially enhancing the overall aesthetics.

De CONE collectie by Osiris Hertman, geïnspireerd op de greep van een kluis, kenmerkt zich door haar statige en tijdloze karakter. De nek van de deurkruk loopt taps toe waardoor er een karakteristieke kegelvorm ontstaat. Dankzij de rozetloze uitvoering van deurkruk lijkt het alsof deze op de deur zweeft. Het sublieme afwerkingsniveau van de uit één stuk gefabriceerd deurkruk is verbluffend en getuigt van technische precisie. Het naadloze design geeft de ruimte een gevoel van rust, waardoor de esthetiek van het interieur compleet wordt.



reddot award 2021  
winner



# by Osiris Hertman

**“A door handle is the crowning jewel of your home – it’s always there, always visible. We’ve chosen a clear, sturdy design with a conical shape and removed the rosette by concealing the technology in the cone section.”**

## **Santpoort-Zuid, the Netherlands**

**Design philosophy:**  
I like to incorporate landscapes into my interiors, guided by the essential influence of nature. I believe nature can teach us everything we need to know about design: the warmth of clothing, the softness concealed within hard materials, even flexibility and cohesion. Because that’s what really counts when it comes to interiors: that every last detail is in harmony with the rest.

**Designed for FORMANI:**  
CONE

**Design award:**  
Red Dot Design Award 2021

**Photography:**  
Carli Hermès



# CONE

## Total concept

### Door fittings

Lever handles  
Lever handle accessories

### Window fittings

Tilt and turn window handles

### Front door fittings

Front door knobs  
Pull handles

### Accessories

Cabinet knobs

### Deurbeslag

Deurkrukken  
Accessoires deurkrukken

### Raambeslag

Draaikiepbeslag

### Voordeurbeslag

Voordeurknoppen  
Grepes

### Accessoires

Meubelknoppen

**366**

366

366

**367**

367

**368**

368

368

**368**

368

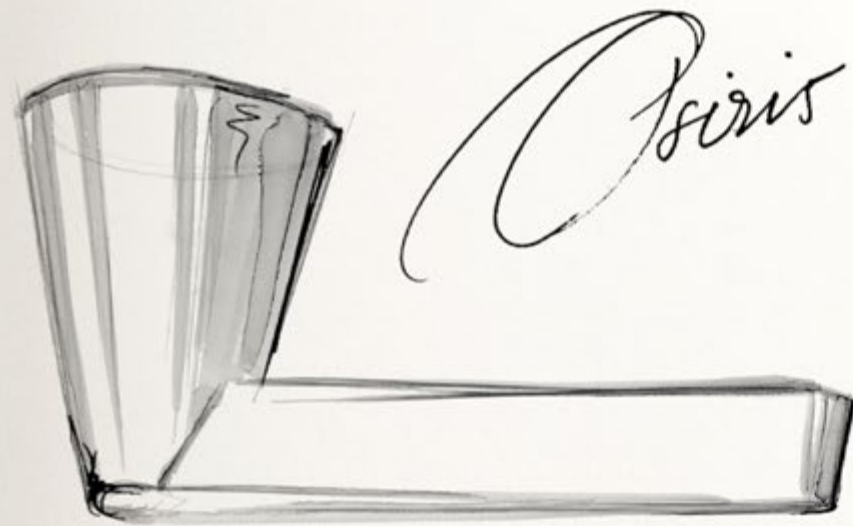
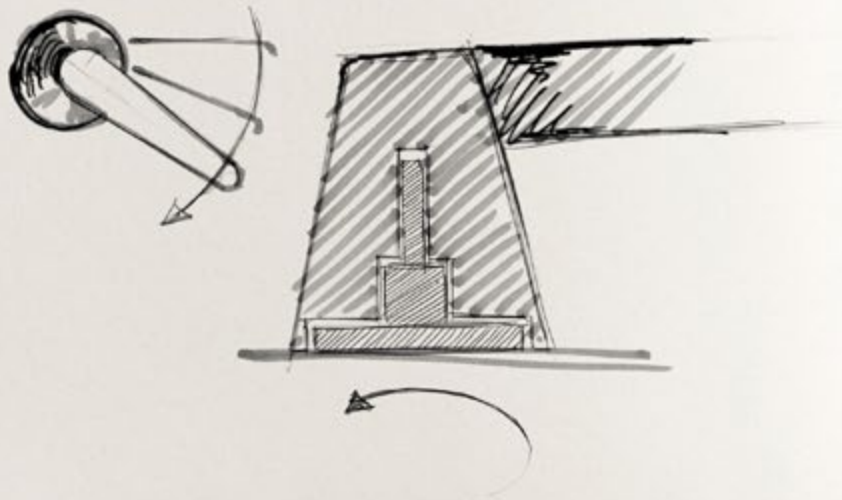
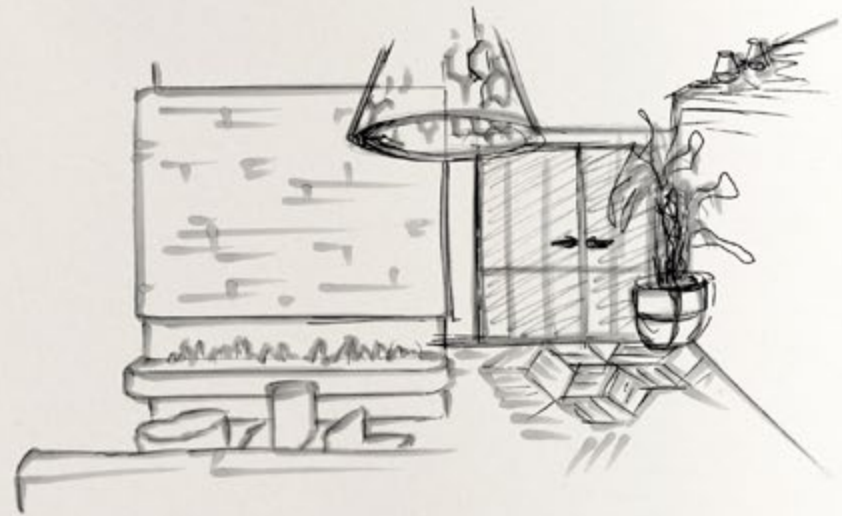



CONE OH100  
PVD satin black





CONE OH100  
satin stainless steel

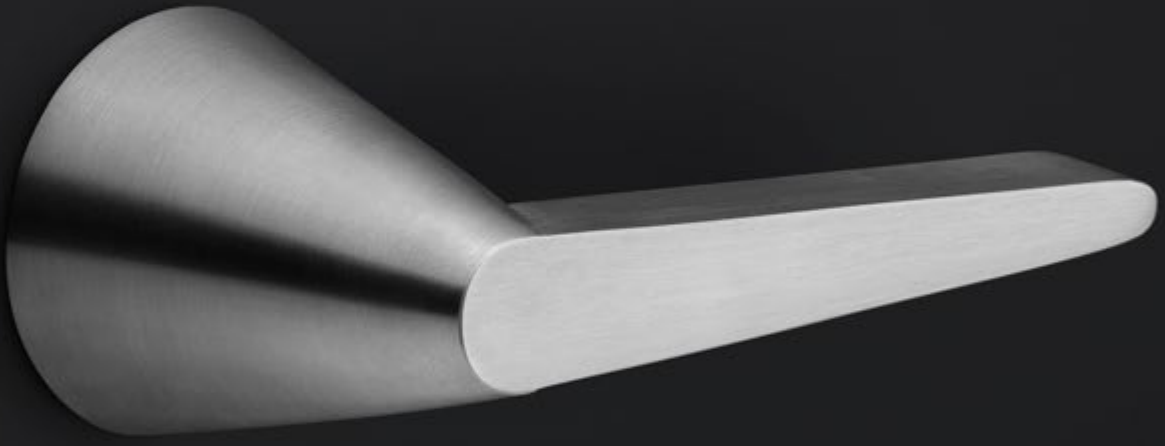

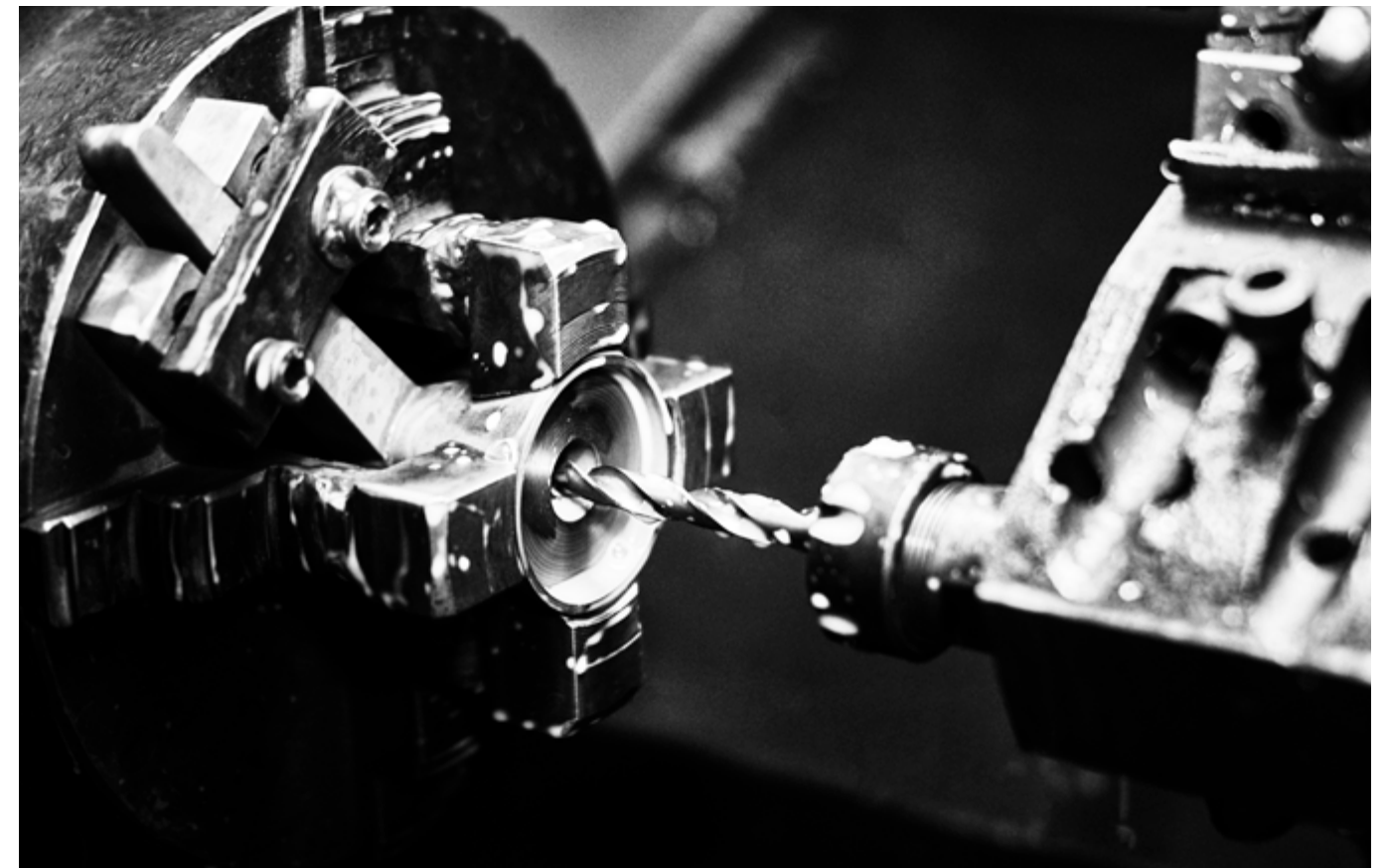

# In detail

## The language of touch

The first touch is decisive. Weight, balance and form determine how a handle feels, even before it is consciously considered. A certain sense of solidity can contribute to a perception of quality, while subtle variations in radius and angle follow the natural movement of the hand.

The interaction itself is equally important. A quiet, controlled rotation reinforces a sense of precision and trust. At this level, quality is not explained but experienced in the moment of use.

De eerste aanraking zet de toon. Gewicht, balans en vorm bepalen hoe een kruk aanvoelt, nog vóórdát er bewust over wordt nagedacht. Een zekere massiviteit kan bijdragen aan een gevoel van kwaliteit, terwijl subtiele variaties in radius en hoek de natuurlijke beweging van de hand volgen.

Ook de interactie zelf is bepalend. Een stille, gecontroleerde rotatie versterkt het gevoel van precisie en vertrouwen. Op dit niveau wordt kwaliteit niet uitgelegd, maar ervaren in het moment van gebruik.



CONE OH100  
PVD satin black

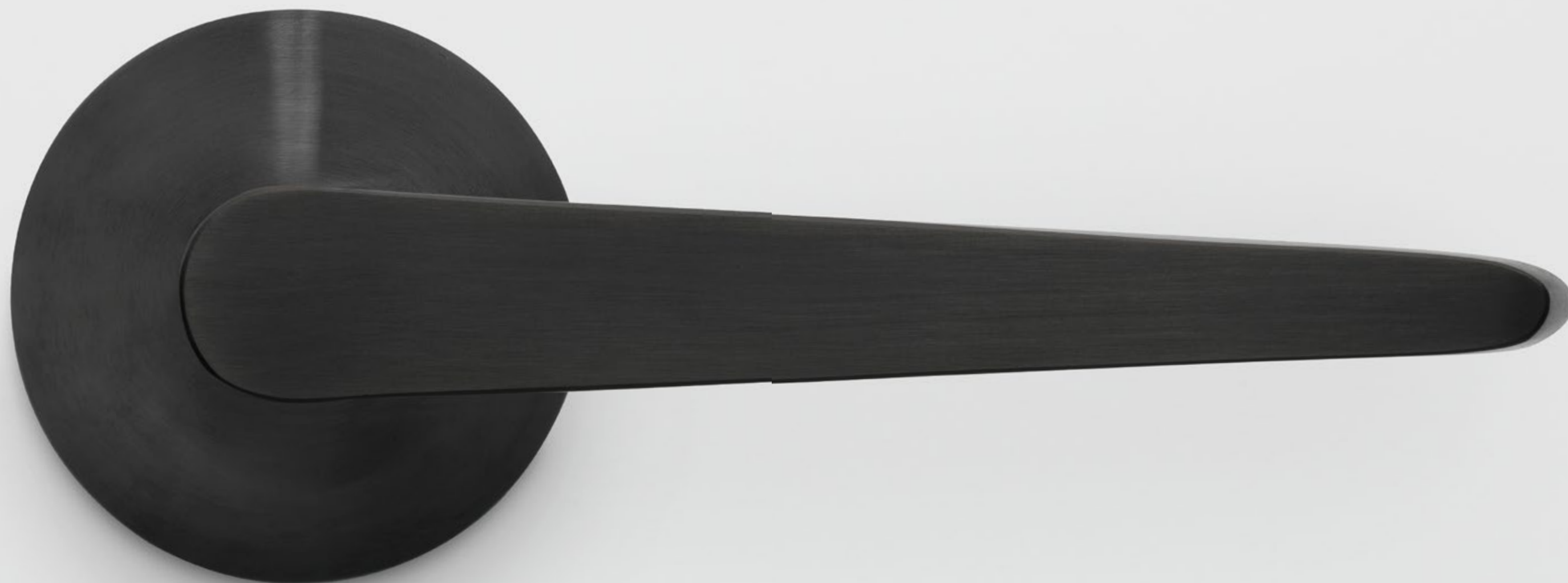

# Haarlem, The Netherlands

## Artistry and clarity

CONE reference: Colourful Jungle

Interior design: Osiris Hertman

Photography: Sonja Velda

Product: CONE OH100 PVD satin black (left),  
CONE OH32M PVD satin black (below),  
CONE OH200V bronze (next page - left),  
CONE OH100 bronze (second-to-last page),  
CONE OH400 bronze (last page)





In his private residence in Haarlem, Osiris Hertman brings together expressive art, layered colour and natural textures in a carefully composed interior. The atmosphere feels personal and bold, yet controlled through refined detailing and clear spatial choices.

The CONE collection by Osiris Hertman integrates naturally into the interplay of colour, material and form, adding a sculptural accent that supports the overall composition.

In zijn privéwoning in Haarlem brengt Osiris Hertman expressieve kunst, gelaagde kleurpaletten en natuurlijke texturen samen in een zorgvuldig opgebouwd interieur. De sfeer is persoonlijk en uitgesproken, maar blijft beheerst door verfijnde detaillering en heldere ruimtelijke keuzes.

De CONE-collectie van Osiris Hertman voegt zich vanzelfsprekend in het samenspel van kleur, materiaal en vorm en brengt een sculpturaal accent dat de compositie ondersteunt.





CONE / 360

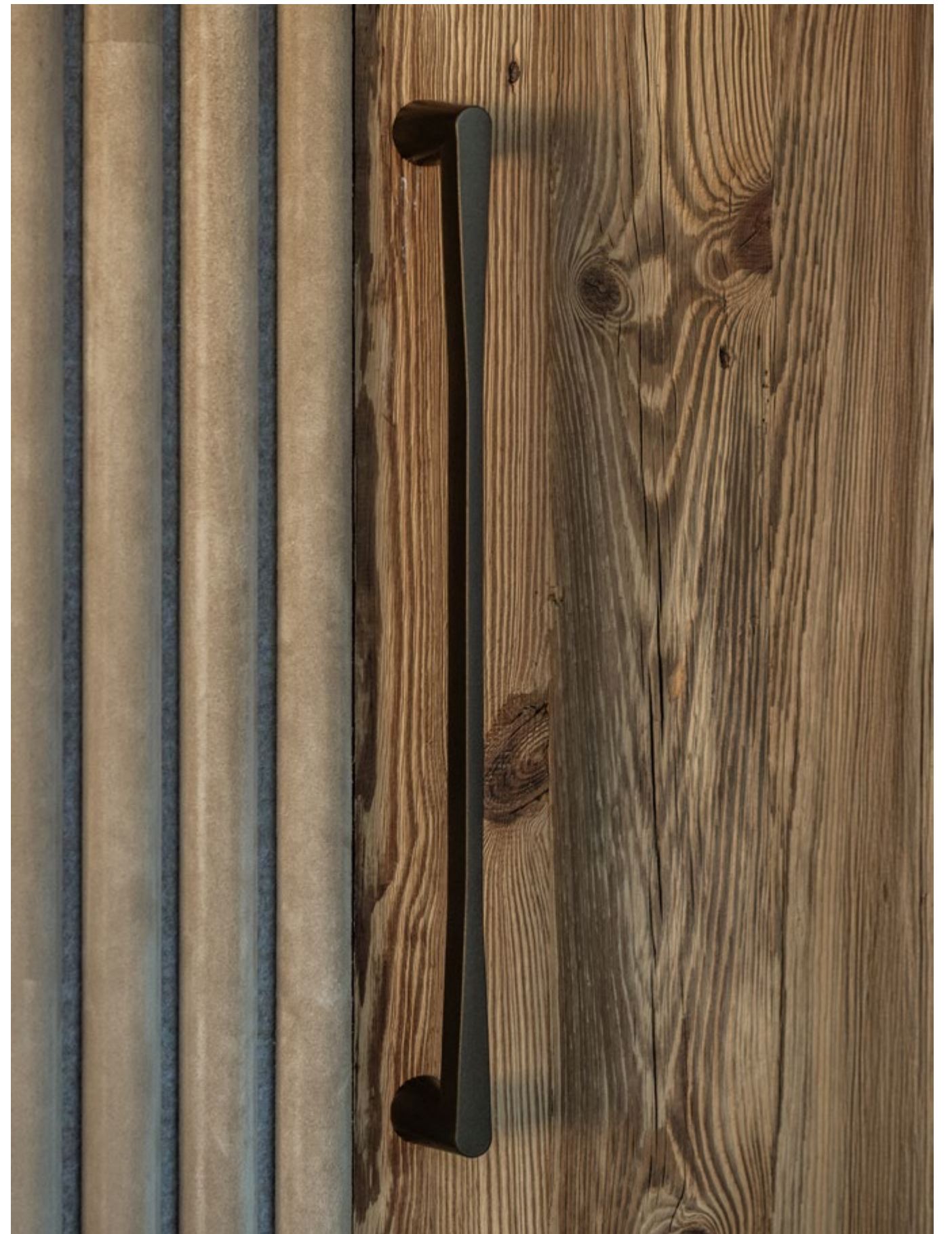

CONE / 361

# Santpoort-Zuid, The Netherlands

**A sculptural residence shaped by natural materials and tapered forms**

CONE reference: Dune Villa

Interior design: Osiris Hertman

Photography: Jurrit van der Waal

Product: CONE OH100 satin stainless steel (left, below),

CONE OH100 PVD satin black (next page - left, next page - right)

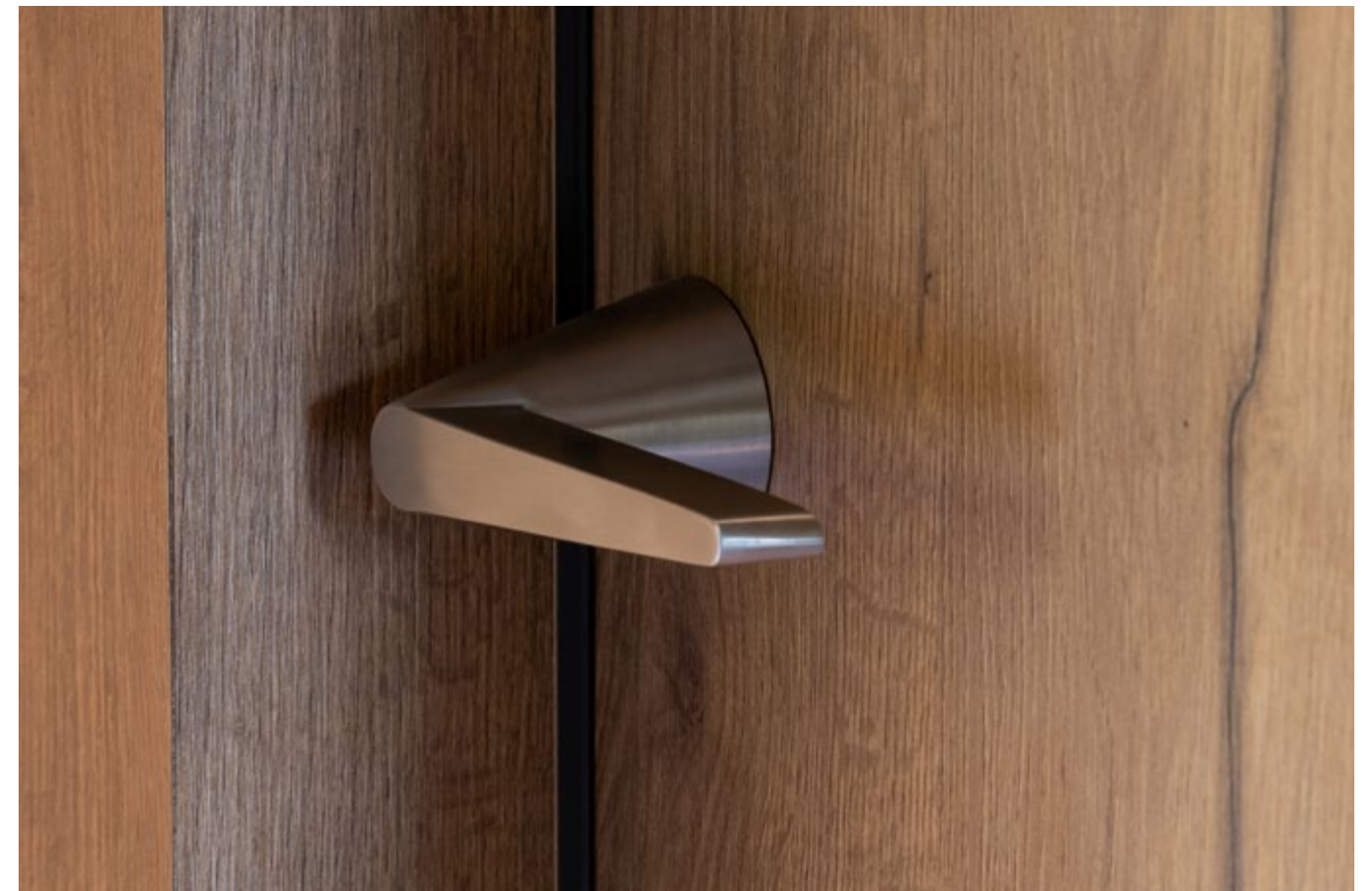



In this private residence in Santpoort-Zuid, Osiris Hertman shapes a warm, sculptural living environment defined by natural materials and crafted detailing. Soft textures, timber surfaces and balanced light create a calm, composed atmosphere.

A separate tiny house in the garden functions as an office and continues the same material-driven language. The CONE collection by Osiris Hertman provides a quiet link between both buildings, connecting home and workspace into one coherent whole.

In deze privéwoning in Santpoort-Zuid creëert Osiris Hertman een warm en sculpturaal leefmilieu, gevormd door natuurlijke materialen en verfijnde detaillering. Zachte texturen, hout en uitgebalanceerd licht dragen bij aan een rustige en samenhangende sfeer.

In de tuin bevindt zich een apart tiny house dat als kantoor dient en dezelfde materiaalgedreven vormtaal voortzet. De CONE-collectie van Osiris Hertman vormt een rustig verbindend element dat woning en werkruimte samenbrengt tot één geheel.



**OH100**



1 5 7

solid sprung or unsprung lever handle on concealed rose

massieve deurkruk geveerd of ongeveerd op verborgen rozet

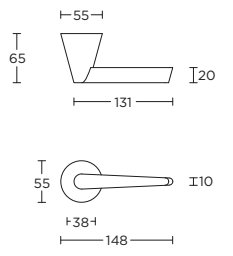

0 OHN54  
 1 OHY54  
 2 OHB54  
 3 OHWC54

formani.com/G001



**OHB54**



1 5  
7

blank escutcheon  
blind plaatje



formani.com/G005

**OHWC54**



1 5  
7

turn and release set  
toiletgarnituur



formani.com/G006

**OH101**



1 5 7

solid sprung or unsprung lever handle on rose with metal sub-rose

massieve deurkruk geveerd of ongeveerd op rozet met metalen onderconstructie

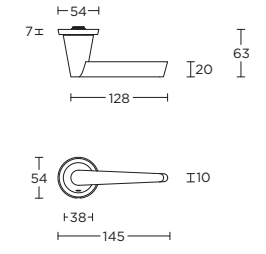

0 OHN54  
 1 OHY54  
 2 OHB54  
 3 OHWC54

formani.com/G002



**OH102-DK**



1 5  
7

non-locking tilt and turn window handle

draaikiepgarnituur niet afsluitbaar

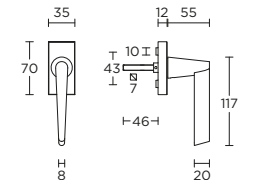

formani.com/G007

**OH102-DKLOCK**



1 5  
7

locking tilt and turn window handle

draaikiepgarnituur afsluitbaar

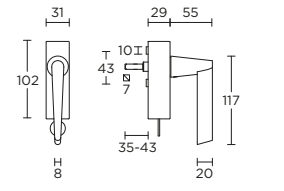

formani.com/G008

**OHN54**



1 5  
7

key escutcheon  
sleutelplaatje

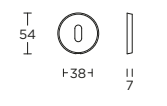

formani.com/G003

**OHY54**



1 5  
7

profile cylinder escutcheon  
cilinderplaatje

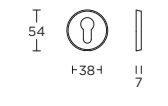

formani.com/G004

- 1 satin stainless steel
- 5 PVD satin black
- 7 bronze

**OH200V**



1 5  
7

solid front door knob fixed on rose  
massieve voordeurknop vast op rozet

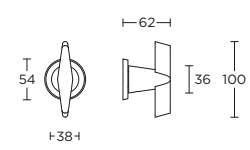

formani.com/G009

**OH400**



1 5  
7

solid pull handle for timber, glass or aluminium doors  
bolt through, concealed or back to back fixings  
massieve greep tbv houten, glazen of aluminium deuren  
doorgaande, niet-doorgaande of paarsgewijze bevestiging



formani.com/G010

**OH32M**



1 5  
7

solid cabinet knob  
massieve meubelknop

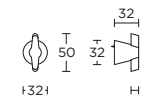

formani.com/G011



# EM DESIGN HANDEL

---

Julius-Hölder-Str. 56

70597 Stuttgart

Tel. 0711-34218605

[info@emdesignhandel.de](mailto:info@emdesignhandel.de)

[shop.emdesignhandel.de](http://shop.emdesignhandel.de)